

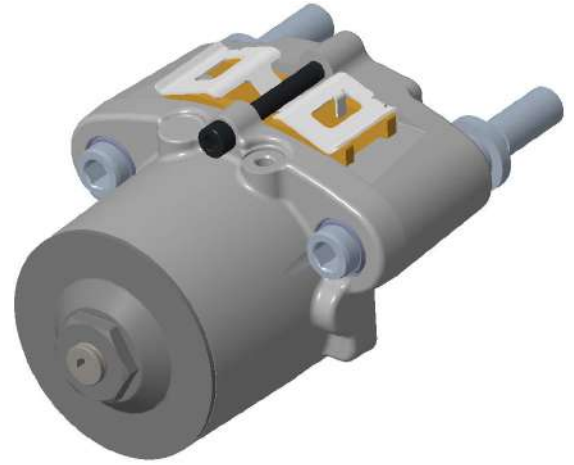

# M100 INTEGRATED SAHR

## FEATURES

- Capable of 44,482 N minimum of park clamp force and 55,602 N maximum
- Actuation mechanism is sealed from the environment
- Durable iron housing
- Self adjusting mechanism
  - Maintains consistent clamp force
  - Eliminates required pad adjustment by end user
  - Minimizes warranty due to end user interface
- Compact size ideal for drive line mounting
- Low hold-off pressures (Hyd Oil)
- Damped mount with positive pad retention & retraction
- Common tool manual release access



## SPECIFICATIONS

Series	Heavy Duty Park caliper
Rotor Diameter	254 to 1016mm
Rotor Thickness	9.5 to 31.75mm
Lining Type	Sintered
Total Lining Area Per Pad	43.5 cm <sup>2</sup>
Weight	14.5 kg
Min Hold-off Pressure	100 Bar
Max Operating Pressure	207 Bar
Max Hold-off Volume	80 ml
Initial Fill Volume	52 ml

## REFERENCE DIMENSIONS

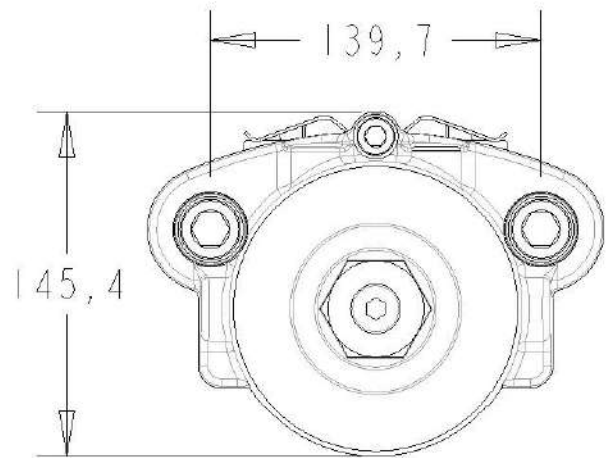

## TORQUE INFORMATION

